

Taurus Planetary Countercurrent Mixer

PGM 500 - 333

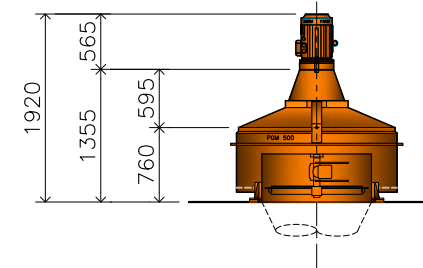
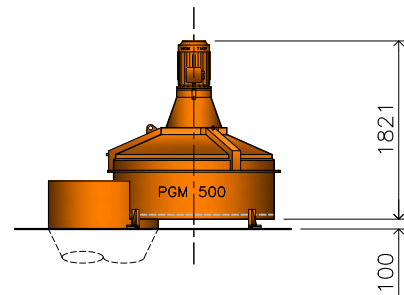
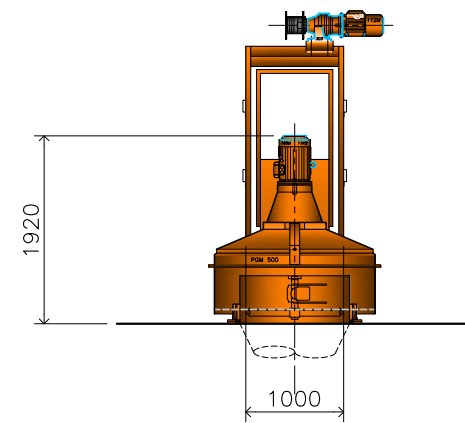
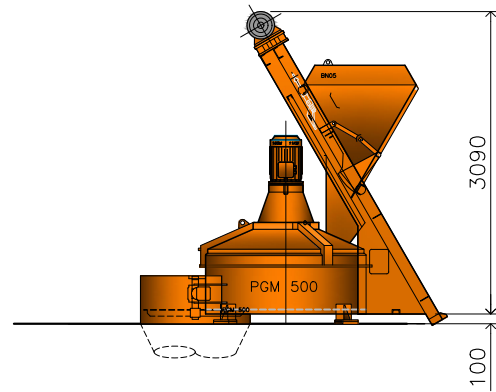
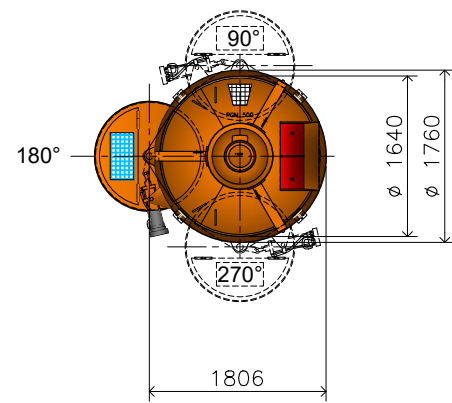

Technical data Planetary Mixer Taurus PGM 500 / 333

Dry filling capacity	Ltr	500
Output per batch, compacted	Ltr	333
Mixer drive motor	kW	11
Mixing stars	n°	1
Mixing shovels / mixing star	n°	2
Mixing shovels width	mm	2 x 360
Side scrapers	n°	1
Side scrapers width	mm	480
Speed of rotor	Rpm	18,2
Speed of mixing stars	Rpm	46,2
Water spray nozzles	n°	2
Weight of mixer	kg	1800

Technical data skip-hoist Taurus PGM 500 / 333

Dry filling capacity	Ltr	500
Max filling weight	kg	750
Hoist drive motor	kW	4
Speed of hoist up / down	n°	0,4 / 0,8
Dia. of hoisting wire	mm	10

